

For additional information see Technical Tips on pages BC1-BC2.

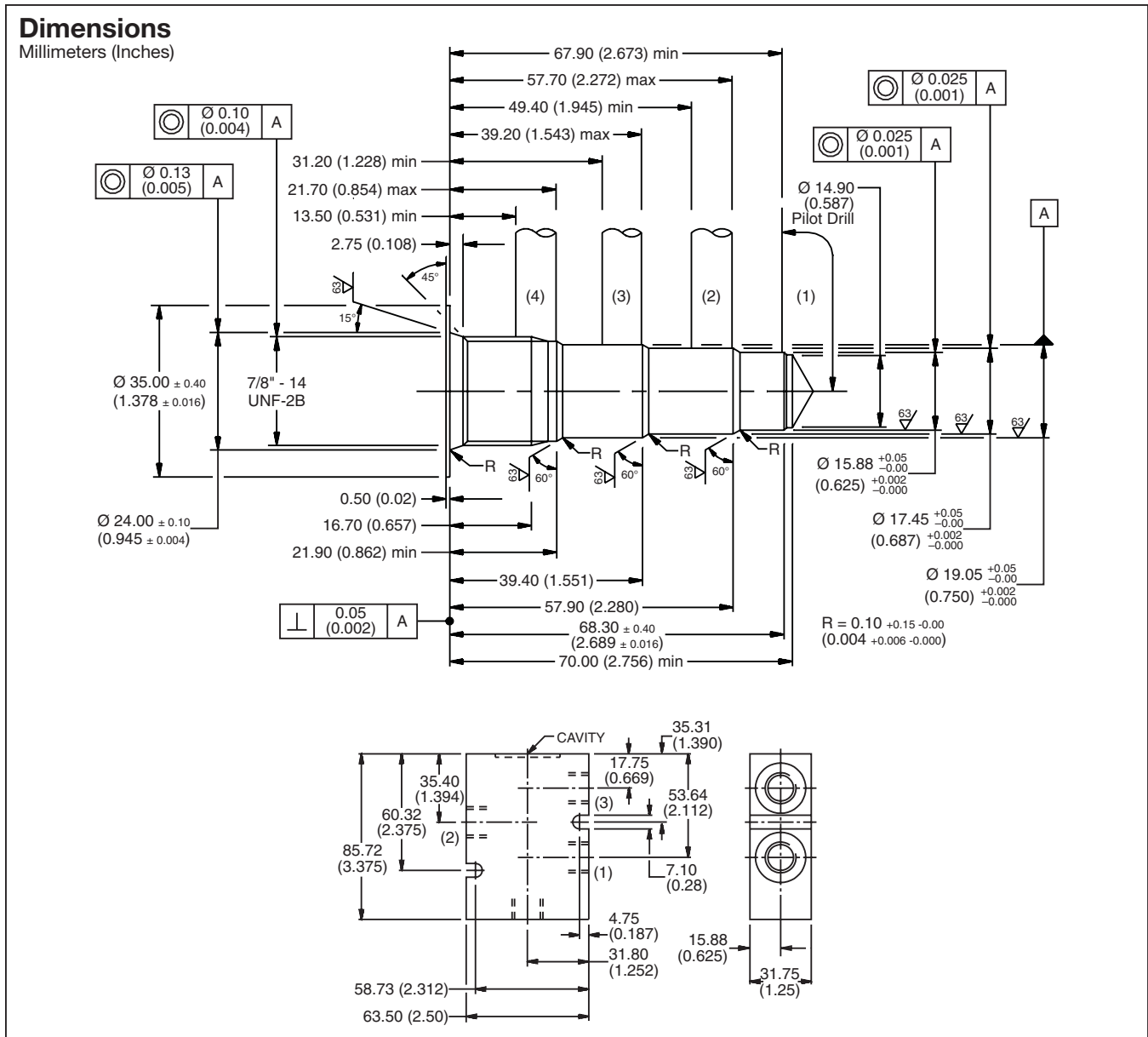

Ordering Information

LB10

Line Body Port Size Body Material

Code	Port Size
562	1/2 SAE

Code	Body Material
A	Aluminum
S	Steel

Cavity Tooling For 4C	
Pilot Drill \varnothing	14.90 (0.587)
Step Drill	8DS31346
Reamer (Alum)	8RM31063A
Reamer (Steel)	8RM31063S
Counterbore	—
Tap	8TP31201

**Please be advised that this is a non-core line body. Additional lead-time and/or pricing requirements may exist when ordering.*



- CV
- Check Valves
- SH
- Shuttle Valves
- LM
- Load/Motor Controls
- FC
- Flow Controls
- PC
- Pressure Controls
- LE
- Logic Elements
- DC
- Directional Controls
- MV
- Manual Valves
- SV
- Solenoid Valves
- PV
- Proportional Valves
- CE
- Coils & Electronics
- CB
- Cartrpак Bodies
- BC
- Bodies & Cavities
- TD
- Technical Data